

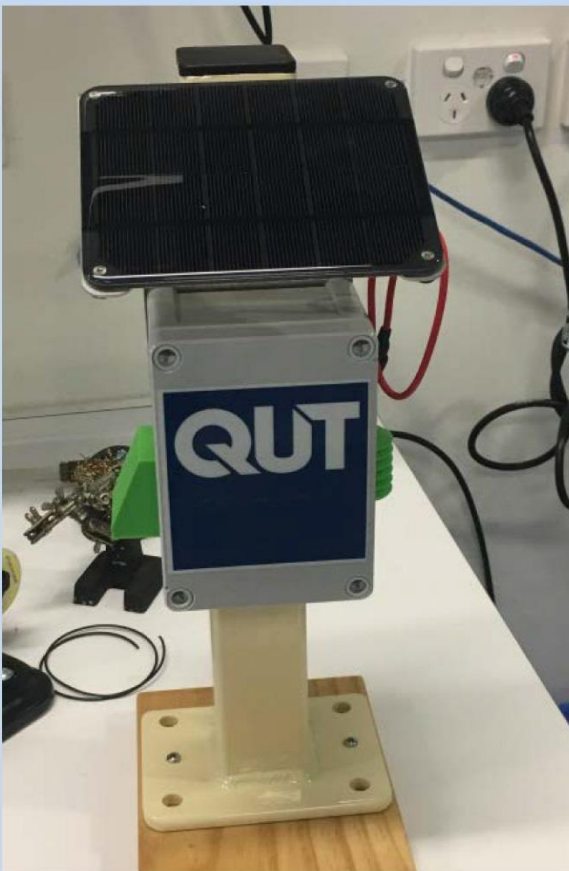

## KNOWING OUR AMBIENT LOCAL AIR QUALITY



### *Automatic Monitoring of Air Quality*

Real time measurement of airborne particle mass and carbon monoxide concentration.

Transmission of data to a central data storage facility.



### CONTACT

**International Laboratory for Air Quality and Health  
Institute for Future Environments  
Queensland University of Technology**

2 George Street Brisbane QLD 4001 Australia  
Phone +61 7 3138 1133  
Email: [ilagh@qut.edu.au](mailto:ilagh@qut.edu.au)

Website

[research.qut.edu.au/ilagh/projects/koala-sensors/](http://research.qut.edu.au/ilagh/projects/koala-sensors/)

Useful Links

<http://data.sensors.net.au/>



The **KOALA** (*Knowing Our Ambient Local Air Quality*) was designed and assembled by the International Laboratory for Air Quality and Health and the Institute for Future Environments, Institute for Health and Biomedical Innovation, Queensland University of Technology, Brisbane, Australia, within the scope of the Australian Research Council Linkage Project LP160100051.

It is a stand-alone solar/battery-operated monitor that measures airborne particulate matter and carbon monoxide concentrations and wirelessly transmits the data to a cloud based storage facility (DMC) built on Amazon Web Services.

The Data Management Centre (DMC) is a secure, backed up cloud architecture which stores and processes sensing data in near real-time from the field devices, providing interactive graphing of sensor outputs, summary 24 averages, historical CSV data access and a map based visualisation delivered through a mobile friendly website. It allows quick analysis of the health of field devices and diagnostic information about the performance of the hardware.

Exploiting advances in Internet of Things (IoT) technology, the KOALA can be configured to use LoraWAN, WiFi, Bluetooth or cellular (3G) communications. Each unit contains two low-cost air quality sensors - a Plantower PMS1003 sensor to measure aerosol particles and an Alphasense CO-B4 sensor to measure carbon monoxide. Additionally, it includes onboard temperature and humidity sensors and dedicated connectors for interfacing to a Global Positioning System (GPS) and light sensor. A versatile power management system allows input from battery, mains (via USB) and solar sources with onboard software allowing sensor level power management for extended field operations. Additionally, the data is stored in a built-in SD card from which they may be downloaded directly on to a computer.

The KOALA may be attached to a wide-range of structures such as walls, lamp posts, and trees. It can also be used in mobile monitoring, such as on motor vehicles. In these applications, the unit comes with a solar panel to keep the battery charged for extended use. For indoor air monitoring, the monitor may be powered through a mains adapter. It can also be used for personal exposure monitoring, where it may be carried on the person. Around 100 of these monitors have been successfully installed and used in many applications in Australia and overseas over the past few years. They are presently monitoring outdoor air quality at fixed locations in Brisbane, Sydney, the Blue Mountains, Adelaide, Fiji, Vietnam, China, Sri Lanka and the Solomon Islands.

Here are some projects where they have been or are being employed successfully:

1. Monitoring air quality at the Commonwealth Games in the Gold Coast, 2018. <https://research.qut.edu.au/ilagh/projects/thegoldcoastanditsair/>
2. Assessing the effect of emissions from cruise ships on the air quality at Port Melbourne, 2019. <https://research.qut.edu.au/ilagh/projects/koala-sensors-port-of-melbourne/>
3. Assessing the impact of dust emissions from coal trains in Brisbane. <https://research.qut.edu.au/ilagh/projects/monitoring-dust-emissions-from-coal-trains/>

4. Monitoring the impact of smoke from controlled burning events in the Blue Mountains. Ongoing. <http://bluemountains.sensors.net.au/>

### Basic Parts and Specifications

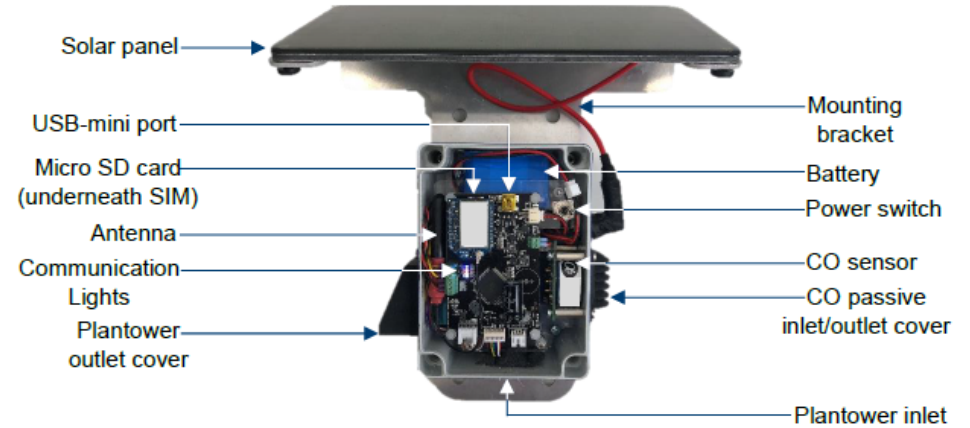

<b>Measurements LxWxB (mm)</b>	255 x 220 x 125 140 x 140 x 77 (w/o panel and bracket)	<b>Particle sensor</b>	Plantower PMS1003 •Optical sensor measuring particle sizes of greater than 0.3µm, 0.5µm, 1µm, 2.5µm, 5µm & 10µm •Conversion to PM <sub>1</sub> , PM <sub>2.5</sub> , PM <sub>10</sub>
<b>Software</b>	Arduino – Sampling and send time changed here (min. 5 sec sample)	<b>Carbon monoxide sensor</b>	Alphasense CO-B4 •4-electrode passive gas sensor
<b>Communication</b>	3G/LoraWAN	<b>Other sensors</b>	In-box temperature and relative humidity
<b>Battery</b>	4V – can last up to 36 hours without recharge on 5 min sampling time and communication every 30 min	<b>GPS</b>	Can be fitted if desired

[data.sensors.net.au](http://data.sensors.net.au)



## Appendix A: Detailed Specifications of the Sensors

### The Plantower PMS1003

#### Overview

The PMS1003 is a low-cost sensor, which can be used to obtain the number and mass concentrations of suspended particles in the air, and output them in the form of digital interface. Its small form factor allows the sensor to be incorporated into a variety of instruments for the continuous monitoring of suspended particle concentration in the air or other environmental improvement equipment.



#### Working principle

The PMS1003 uses a laser scattering principle to radiate suspending particles in the air, then collect the scattered light which can be related to the particle size and concentration distribution. The sensor's onboard microcontroller then calculates the equivalent particle diameter and the number of particles with different diameter per unit volume based on MIE theory. Figure 1 shows the Please find the functional diagram of the sensor.

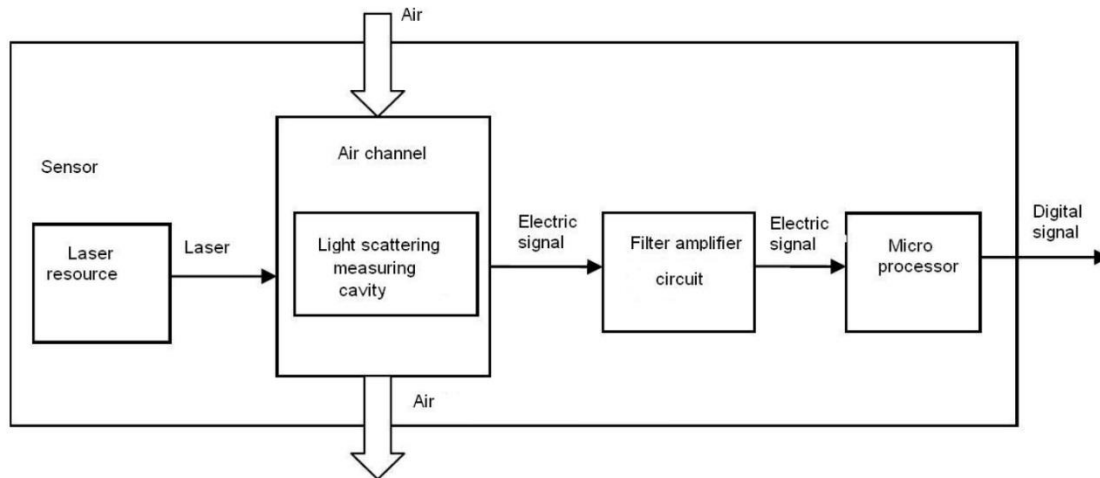

Functional block diagram of sensor

The Plantower PMS1003 sensor provides direct readings of particulate matter in units of  $\mu\text{g m}^{-3}$  in three size ranges, up to 1.0  $\mu\text{m}$ , 2.5  $\mu\text{m}$ , 10.0  $\mu\text{m}$ , together with the particle number concentrations (PNCs) in six size bins, 0.3, 0.5, 1.0, 2.5, 5.0 and 10.0  $\mu\text{m}$ , simultaneously.

Technical Parameter	Index	Index	unit
Range of measurement		0.3~1.0; 1.0~2.5; 2.5~10	Micrometer ( $\mu\text{m}$ )
Counting Efficiency		50%@0.3 $\mu\text{m}$ 98%@>=0.5 $\mu\text{m}$	
Effective Range (PM2.5)		0~500	$\mu\text{g}/\text{m}^3$
Maximum Range (PM2.5)		$\geq 1000$	$\mu\text{g}/\text{m}^3$
Resolution		1	$\mu\text{g}/\text{m}^3$
Maximum Consistency Error (PM2.5 standard data)*		$\pm 10\%$ @100~500 $\mu\text{g}/\text{m}^3$ $\pm 10\mu\text{g}/\text{m}^3$ @0~100 $\mu\text{g}/\text{m}^3$	
Standard Volume		0.1	Litre (L)
Single Response Time		<1	Second (s)
Total Response Time		$\leq 10$	Second (s)
DC Power Supply		Typ:5.0 Min:4.5 Max: 5.5	Volt (V)
Active Current		$\leq 100$	Milliampere (mA)
Standby Current		$\leq 200$	Microampere ( $\mu\text{A}$ )
Working Temperature Range		-10~+60	$^{\circ}\text{C}$
Working Humidity Range		0~99%	
Storage Temperature Range		-40~+80	$^{\circ}\text{C}$
Physical Size		65x42x23	Millimeter (mm)

[http://www.aqmd.gov/docs/default-source/air-spec/resources-page/plantower-pms1003-manual\\_v2-5.pdf](http://www.aqmd.gov/docs/default-source/air-spec/resources-page/plantower-pms1003-manual_v2-5.pdf)

### The Alphasense CO-B4

**Sensitivity:** CO 420 to 650 (nA/ppm at 2ppm)

**Response time:** < 25 (t90 (s) from zero to 10ppm CO)

**Zero current:** +30 to -130 (nA in zero air at 20 $^{\circ}\text{C}$ )

**Noise\*:** 4 ( $\pm 2$  standard deviations (ppb equivalent))

**Range:** 1000 (ppm limit of performance warranty)

**Linearity:** 20 to 35 (ppb CO error at full scale, linear at zero, 500ppm CO)

The CO sensor provides two voltage outputs: working voltage (We, mV) and auxiliary voltage (Aux, mV). These two readings are used to calculate the CO concentrations.

$$CO (conc.) = \frac{(We - Vo) - (Aux - Auxo)}{Sensitivity}$$

In this formula, Vo, Auxo, Sensitivity are specific values for each sensor that are provided by the manufacturer.

<http://www.alphasense.com/index.php/air/downloads/>



